

# Mechanalysis (India) Limited



## Condition Monitoring Solutions for Conveyors

Author: Peter W. Hills, Dipl. Man, MBA, FlntNDT, FlntDiag Engs  
Managing Director & CEO

### White Paper WP10

#### Contents:

#### Page

ABSTRACT .....	2
1 INTRODUCTION .....	3
2 MAINTENANCE MANAGEMENT .....	3
3 VIBRATION MONITORING WILL NOT WORK ON MOST CONVEYORS .....	3
4 CONVEYORS OPERATING IN INDUSTRY .....	5
5 CHALLENGES OF MAINTAINING CONVEYORS .....	6
6 IDENTIFYING & SELECTING A CONVEYOR MONITORING SYSTEM .....	7
7 CONDITION MONITORING OPTIONS FOR CONVEYORS.....	8
7.1 Off-Line AE Systems for Bearing & Lubrication Distress Monitoring .....	8
7.2 On-Line Acoustic Emission Systems for Super Slow Machine Drives.....	9
7.2.1 On-Line Intelligent Motor Condition Monitoring.....	9
7.2.2 How Does MCM Work?.....	10
7.2.3 MCM – Selected Successes and Applications .....	12
8 CLOSING COMMENTS.....	13
REFERENCES .....	14

<b>KEYWORDS</b>	Belt Conveyors, Condition Monitoring, Vibration Analysis, Motor Current Analysis, Acoustic Emission, Maintenance Management, Uptime
<b>PARTNERS</b>	Artesis UK, Beran UK, Commtest NZ, Hansford UK, Holroyd UK, QPS Photonics Canada, Sonsonics UK, Mobius Australia.

#### Mechanalysis (India) Limited

Reg. Office: 47-48 Jolly Maker Chambers II, Nariman Point, Mumbai, 400 021, India  
Tel.: +91(22)2202 7430 Fax: +91(22)2285 0480 [www.mechanalysisindia.com](http://www.mechanalysisindia.com)

# Condition Monitoring Solutions for Conveyors

Peter W. Hills, Dipl. Man, MBA, FInstNDT, FInstDiag Engs  
Managing Director & CEO, Mechanalysis India Ltd.

## ABSTRACT

In the global competitive environment, production costs must be constantly contained or reduced and extended machinery running time achieved. Those companies producing at the lowest cost will survive; the inefficient will close. To remain in operation every aspect of the process has to be managed to the last detail; optimising conveyor availability will be essential to these objectives.

For over 35 years, vibration based condition monitoring has augmented subjective maintenance experience throughout industry. By applying objective measurements to diagnose rotating machinery health, considerable savings continue to be achieved. However, when applied to conveyors, the outcome has been variable at best due to the erratic quality of the data. Assessing the condition of low and variable speed rotating elements has been a challenge. Conveyor drives, their associated pulleys and idlers are constantly subjected to degradation. The ingress of dust, contamination, overload and lost lubrication with consequential bearing deterioration and seizure are common causes of conveyor failure.

Further, the continuous assessment of the conveyor's electric drive motor has not been very practical. While sophisticated off-line diagnostic tools have been available from specialist external services, these are usually only applied on a periodic basis and at a cost. This unsatisfactory situation has now been overcome by continuously monitoring the electric current using a state of the art intelligent device. At a modest investment, complex data is reduced to easy to comprehend information for Plant Operators or Maintenance Engineers to act upon. Although maintenance expertise is fast becoming a rare commodity, these tools can now replace or enhance the lost skills.

The on-line motor analysis system is complemented by periodic go / no-go acoustic emission measurement techniques for direct bearing assessment and AE on-line super slow machinery monitoring instrumentation. Simple but effective checks on those rotating elements at remote locations such as conveyor idlers will strengthen the tool set. The shortcomings of traditional vibration based monitoring systems are overcome by affordable proven technology. The new condition monitoring solutions discussed will enable Operators to take objective decisions with confidence.

## CONDITION MONITORING KEEPS CONVEYORS CONVEYING

Peter W. Hills

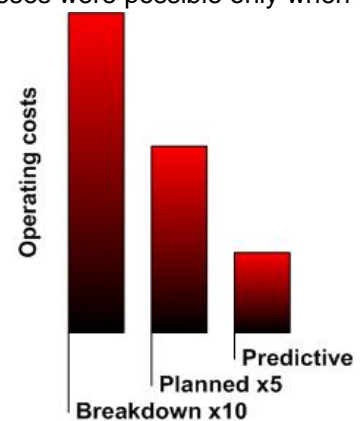
Managing Director & CEO, Mechanalysis India Ltd

### 1 INTRODUCTION

Most conveyor systems are strategic to the process, whether carrying materials or people; appropriate condition monitoring to keep them in operation must be a proven investment. To date it is common to employ specialist analysts or consultants to periodically monitor machines or investigate assumed faults. In many instances, such programmes have not delivered the expected benefits. This is largely due to the process variables and the newer variable frequency drives (VFD) that tend to frustrate periodic overall vibration and frequency band trending. Erratic indications and false alarms are the order of the day. Confidence in traditional vibration based condition monitoring of conveyor health has not been rated very high as a result. With the current global financial meltdown, increasingly competition will become even more acute. Only those manufacturing processes that operate to the optimum efficiency will survive. Production costs have to further reduced and machinery-running times extended. Taking machinery to exhaustion without failure, can achieve a better return on capital assets. This paper discusses new practical and economic condition monitoring solutions that employ intelligent on-line motor condition monitoring to alert and identify specific mechanical and electrical faults. To complement this and for those more remote rotating shafts, portable acoustic emission meters provide objective information for decision making using relatively low skilled operators.

### 2 MAINTENANCE MANAGEMENT

For over 35 years, condition monitoring technologies in industry have successfully augmented subjective maintenance experience by objectively diagnosing rotating machinery health. However, with conveyors, the outcomes have been variable due to the difficulty in converting data into information. In South Africa, like many other emerging and mature economies, experience at the oily rag end of industry is fast diminishing. The day the maintenance engineer could 'listen' to a machine and take appropriate action is long gone. Actually, many such diagnoses were possible only when the damage was at an advanced stage and so the apparent skill was actually limited. Increasingly machinery design and improved power to weight ratio has changed such that subjective maintenance experience can no longer be considered reliable or consistent. Further, results can only be determined at the time of the check, but what happens when one is not there? Any plant breakdown must be unacceptable. Compare the relative costs of Breakdown versus Planned and Predictive Maintenance strategies shown in **Figure1**. Such programmes are only practical if maintenance strategies are associated with a culture of TPM, Six Sigma, TQM, etc. and are implemented at Board level. The management must recognise that maintenance is not simply a cost but a strategic tool for optimising plant availability. No matter how well the plant or proposed beneficial gadget is designed it must have management commitment.



**Figure1**  
Maintenance Costs

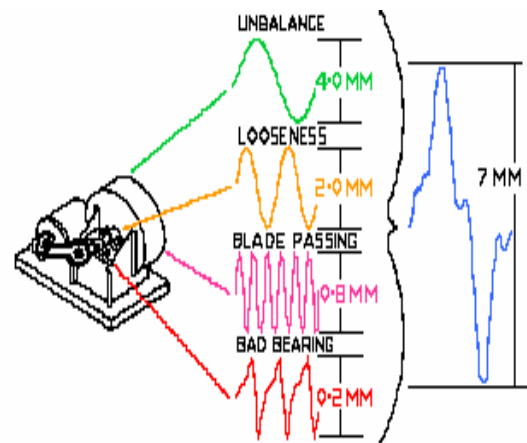
### 3 VIBRATION MONITORING WILL NOT WORK ON MOST CONVEYORS

Vibration based condition monitoring was probably the first technique applied (remember the train wheel tappers) and is still the most widely used machinery diagnostic method. A noisy machine like a crying baby needs attention. However, in the case of belt, roll and plate conveyors it was considered that limited benefit was available from a vibration monitoring programme. The reason is, that traditional vibration measurements are best suited to continuous running constant speed machines and processes. Monitoring data from variable speed shafts is very difficult because the fundamental frequency (1xRPM) will vary from check to check. As a result the orders or harmonics of the 'fundamental' that are associated with subsidiary faults like alignment, looseness and bearings keep changing. Traditional vibration monitoring is generally applied to machines running upwards from

1500 rpm. Slower machines such as cooling tower fans, pumps and hydro generators that run from 150 to 800 rpm require specialised sensors and signal processing circuits. Many ore belt conveyors operate at belt speeds up to 5m/sec with the drive shaft at 50 rpm or even less while feeder belts will run much slower. Without very specialist diagnostic techniques, only the very best equipped and skilled analyst may make sense of minute signals emanating from such low shaft speeds. Any attempt operating a vibration based condition monitoring on conveyors is at best limited and mostly erratic.

On-line machinery protection standards (API670) specify overall vibration measurements (un-filtered signals) as the basis for warning and trip. Specifications are based on the belief that a defective machine will, over time, increase the overall level of vibration until an unacceptable point is reached. While this is true for most rotating machines such as fans and pumps, the rules do not apply to variable and slow speed plant. Variable frequency drive (VFD) motors offer considerable energy savings but vibration monitoring specifications have not caught up with these developments.

At low frequencies, (i.e. lower shaft speed) high-energy signals are generated; typically caused by unbalance, misalignment and looseness. As the frequency (shaft speed or harmonics) increases up the scale, the vibration energy level reduces exponentially. This makes detection of complex high frequency signals from bearings and gear mesh extremely difficult as they are swamped by the dominant main drive signals. It is for this reason that many machines fail without warning yet they have some sort of monitoring systems installed, usually inappropriate! In the case of conveyors, where shaft speeds are generally much lower than most motor drives, detecting the high frequency signals becomes even more difficult because of the limitations of the sensor and signal processing to detect the low energy levels at an early stage.

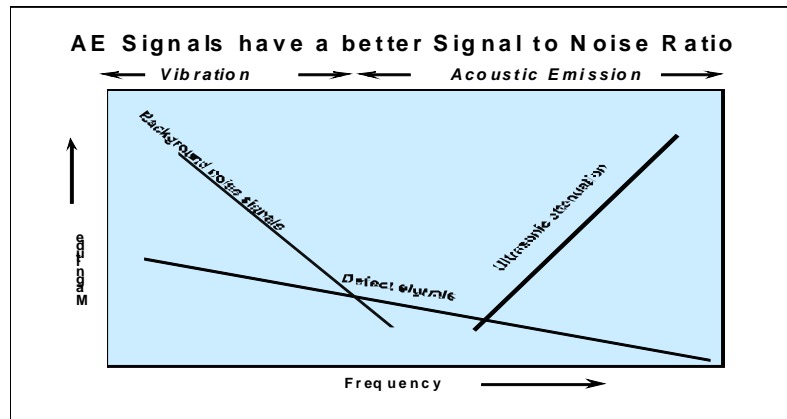


**Figure 2**  
**The Overall Level of Vibrations is the Sum of the Energies at all Frequencies**

With traditional vibration systems on conveyor Plummer blocks for instance, only when the machine is about to leave its foundation, will one recognise a fault. Unfortunately this is all too late and hardly predictive maintenance! **Figure 2** illustrates the individual vibration energy generated by each element totalling 7mm/sec of overall vibration. If we assume the bearing signal alone doubles from 0.2 to 0.4 mm/sec (a 100% increase) then the overall signal will only rise to 7.2mm/sec. Such a small change is likely to be ignored and simply attributed to a measurement variation. The **General Vibration Severity Chart** (Rathbone) states a doubling of the overall signal is indicative of a step change in fault severity. The above example simply illustrates that if a significant fault develops from a high frequency element, such as an antifriction bearing, it will not be obvious. Such faults are likely to be common with conveyors, especially those running at slow speeds. The high frequency component will therefore be masked by the ambient vibrations of the larger mass system and likely to remain undetected until virtual failure.

Fault frequency data will also be lost when Control and Instrumentation specify that the vibration AC signal is required to be converted to DC (4-20mA) to interface with their control system. This is common with loop powered accelerometers are wrongly applied. When this happens over 80% of the useful vibration information is discarded since no analysis can be undertaken on a DC signal. Only diagnostics of the AC signal will reveal the true condition of the rotating elements if the test circumstances are suitable. In the case of the low speed conveyors, detection is even more problematical despite the availability of sophisticated FFT spectrum and enveloping or demodulation bearing analysis techniques.

**Figure 3** (right) illustrates the relationship between energy and signal detection as the frequency increases. The background noise signals are those detected as vibration and in the mainly audible range whereas the higher frequency signals are ultrasonic. The machine elements generating the highest energy are generally low frequency (10-1KHz) and hence easily detectable by traditional vibration meters.



**Figure 3: Defect Signal Energy Reduces as Frequency Increases**

It will be argued that specialised Fast Fourier Transform (FFT) analysers can detect faults at the higher frequencies, (>40KHz) in the frequency domain but for these, expert diagnostic skills are essential. Acoustic Emission (AE) techniques on the other hand are suited to detect anomalies emitting high frequency signals from bearings, gears, etc. Because AE operate around the 100KHz range they have a superior signal to noise ratio. This enables defect acceptance levels to be specified. Since AE readings are taken in the time domain they are not affected by speed variation between tests unlike the frequency domain instruments. AE offers a simple go/no go indication that does not require the expert analyst an advantage where maintenance diagnostic skills are wanting.

#### 4 CONVEYORS OPERATING IN INDUSTRY

The Oxford Dictionary describes a conveyor as “a continuous moving band used for transporting objects from one place to another.” While the Irish-born British mining engineer Richard Sutcliffe is credited with inventing the first conveyor belts for coal mines in 1905, Thomas Edison’s iron ore mines used belt conveyors 20 years earlier! The conveyor belt idler we know today was in fact invented by a Thomas Robbers in the 1890s.

Industry applications are wide, from mining to letter sorting, mechanical, hydraulic and pneumatic machines. All, are delivery systems fundamental to a product’s transformation processes. Imagine if the coal stopped coming on the cable bucket conveyor, the power plant would come to a halt, see **Figure 4**. The ubiquitous escalator we often take for granted is a conveyor. Transportation of people in airports, shopping malls and around cities has become a strategic advantage. Case studies on monitoring Paxcons are outline later.



**Figure 4  
Taking Coal to the Power Plant**

Any waiting time for material to be delivered between transformation is lost time and hence optimising conveyor availability is directly linked to profitability. A literature search of conveyor maintenance problems revealed few references; it is unlikely there are none! Most publications refer primarily to design issues and improvements or catastrophic failures influencing development.

Some of the better known conveyor monitoring systems cover:

- Belt rip detection, typically a pressure sensor under a transfer point.
- Plummer block vibration measurement & analysis
- Belt alignment detection, sensors on each side of the belt.
- Belt speed to detect slipping.
- Level detection in bins to avoid empty condition and direct discharge onto the belt.
- Transfer chute overflow detection.
- Jammed idler detection is reported as highly desirable, if available.

Variable speed drives are usually applied to feeder belts, which are generally relatively short. Both VFDs and hydraulic variable speed drives are common. The typical problems are:

- Overload due to poor feed/transfer chute design or belt under designed.
- Poor belt tracking due to poor feed chute design, bad initial alignment or jammed idlers.
- Belt won't start under full load due to bad feed chute design or conveyor under design.
- Excessive belt wear due to poor transfer chute design or feed size too large.
- The above will also cause high idler wear.
- Excessive spillage due to all the above.

At Beltcon14, **Spriggs** *'Golden Rules'* summarises the failure of the harbour conveyor T1 at a port in Guinea where torque and start up sequencing caused huge direct costs as well as those associated with the ships waiting to be loaded. At an Ash Overland Conveyor in South Africa, structural damage was caused by high torque on the tail pulley when starting up empty. **Lebedev's** *'Dynamic Simulation of Conveyors'* reports that the cumulative effects of conveyor non availability resulted in 29% of a mine's lost production. **Kruse** discusses condition monitoring in *'Data Acquisition Techniques and Measurement Equipment for Belt Conveyors'* with emphasis on motor power monitoring and torque devices associated with strain gauges; state of the art solutions now exist that will resolve many of these reported requirements. The vibration based CM techniques will need to take into account the unique challenge of the conveyor belt. Success with one application will not necessarily be applicable elsewhere since the traditional constant high speed rotating plant is much easier to monitor than low variable speed conveyors.

## 5 CHALLENGES OF MAINTAINING CONVEYORS

Predictive Maintenance is a process of measurements to give advanced warning. Faults detected at the incipient stage enable the planning of tools, spares and plant availability for repairs to be undertaken thus minimising downtime. This strategy has proven to be beneficial worldwide.



**Figure 5**

### Typical Dust Likely to Contaminate Machinery Elements

Conveyor drives of all types are sensitive to system degradation and contamination where lack of lubrication and bearing deterioration are most common. **Figure 5** illustrates the challenge machine designers must consider. The presence of fine dust will ultimately enter moving parts, clog-up ventilation airways causing wear and over-heating. The emphasis on 'housekeeping' cannot be overstated. Despite all precautions, the inevitable maintenance emergency in the early hours of the morning often results in covers left off, grease nipples unsealed, oil filler caps missing, etc leading to deterioration.

The ingress of silica-based material (most common) to the moving elements, aided by grease, creates a grinding compound that will accelerate bearing failure. Traditional overall vibration checks on bearings and temperature measurements are usually only effective when deterioration is at an advanced stage, often too late. While the Mechanical Engineer has a range of test meters at his disposal, the Electrical Engineer usually has had to rely on the simple panel wattmeter and physical inspections during shut downs. We know that the drive motor is subjected to significant load changes, high torque, etc. that stresses the electrical windings, insulation, connections, etc. To date, to monitor the condition of electric motors required specialised motor current analysers for assessing harmonics, phase, air gap, etc. These periodic checks are often invasive requiring plant to be shutdown. Electrical tests are generally undertaken by external services, if locally available. However they tend to interrupt production causing lost productivity. This is not necessary with affordable on-line motor monitoring systems that are now available.

## 6 IDENTIFYING & SELECTING A CONVEYOR MONITORING SYSTEM

Belt conveyor systems consist of a supporting structure, one or more drive motors, a tail pulley (that may also drive) and idlers every metre or so. Conveyor lengths can vary from a few metres to many kilometres. Machinery is often located in inhospitable environments subject to dust and all weather conditions. Only the rotating elements and electrical drives are addressed in this paper.

The typical rotating machinery faults are likely to be:

- Burn-out drive motors due to excessive load and varying torque.
- Worn motor bearings due to overload, contamination and/or lack of lubrication.
- Guide and Tail Pulley bearing wear amongst the many rotating shafts.
- Seized idler bearings due to lack of lubrication and contamination.

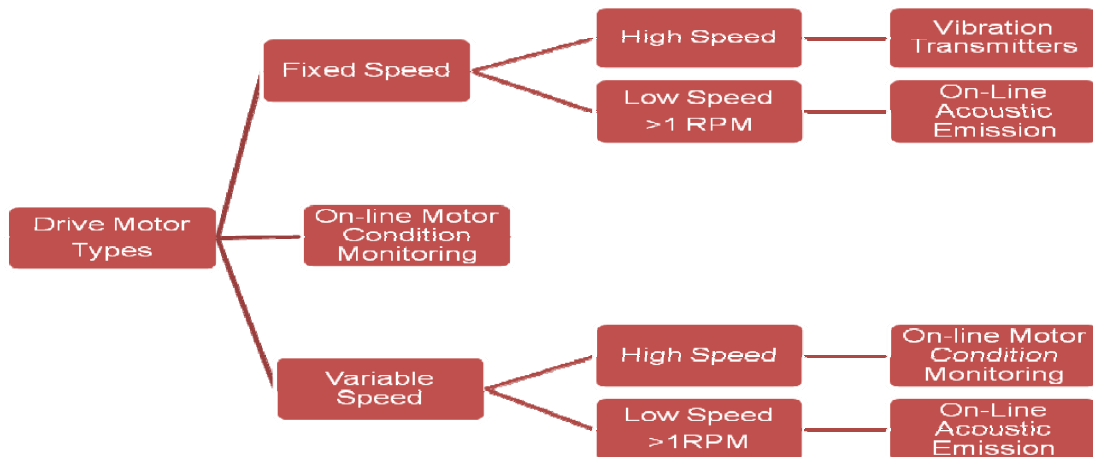
Monitoring the above associated rolling elements call for different strategies. The main challenge is the cost of installation to transmit clear information to the Operations or Maintenance Departments. The system must be reliable and not become a maintenance liability in itself. False Alarms are the worst outcome of any monitoring instruments since once confidence is lost Operations will then ignore the valid signals.

The drive motor **Figure 6** is usually located near Control Centres. Sensors to monitor the prime mover are easily installed and data distributed. A system that monitors both the drive system, the gearbox as well as the electrical motor is the optimum solution.



**Figure 6:**  
Conveyor Drive Motor

To select the fault detection options, the key criterion is to understand the root cause of potential failure and then match the appropriate detection system. Initially the decision must be based on the prime driver functions. The guide chart below (**Figure 7**) illustrates monitoring options:



**Figure 7:**  
Selection Table for a Condition Monitoring System

It is essential for the electric drive motor to have an on-line motor condition monitoring system and then complementary sensors based on the mechanical protection required. This hybrid solution will provide advanced warning to Operations of fault development in the electrical and/or the mechanical system. A reporting system must indicate the basic fault type to aid rapid decision-making. If, for example a bearing is suspect, portable meters will identify the specific bearing. If further detailed analysis is necessary, 'Demodulation' signal processing with a FFT Analyser can trace the fault's progression from inner to outer race, ball pass and cage frequencies. For very slow conveyor drives,

including gearboxes, on-line AE monitoring techniques can assess such highly loaded gears and bearings rotating down to as low as 0.25rpm. The plant's condition status can be made available to Control Centres in almost any format required through a SCADA system.

For multiple rolls and idlers, especially those in remote sites, periodic acoustic emission meters will identify idler bearing Distress® without the need to refer to historical trends. This makes AE the most practical and economic for large conveyor systems. Further since non-drive tail pulleys, guide rollers and multiple idlers etc are spread over considerable distances, it is unlikely to be cost effective to place permanent sensors on each bearing point. While AE systems are available to monitor multiple rolling elements for lightweight compact conveyor systems, such as letter sorting, these would not be suitable for the industrial conveyor at the current stage of sensor development.

Periodic measurement of the many hundreds of idlers can be done rapidly with go/no go results using a portable device. **Figure 8.** shows the AE meter assessing bearing Distress®. The advantage of the system is that, unlike vibration, the sensor is not sensitive to a specific shaft orientation; anywhere near to the bearing area will be sufficient. In addition, irrespective of the age of the plant the AE system will still give immediate results. Readings below Distress® 5 are good, 5-10 OK, 10-15 problem developing, >15 poor, re-grease and recheck. After greasing the signal will most likely reduce to acceptable limits and if it remains low for 24 hours then the problem was only lack of lubrication. The simple act of applying grease flushes out any debris thus extending the life of the rotating elements.

Many may claim that periodic vibration tests have already been attempted on Plummer blocks but experience shows the results have been inconclusive or erratic at best. This is not surprising since if overall vibration readings, bearing spike energy, shock pulse or demodulation techniques were applied. None of these will produce reliable data due to the low shaft speed variations as well as load between tests. Such traditional vibration based systems depend on long-term trend data with advanced data management systems. Simply put, this measurement technology is just not suitable for most conveyor applications. AE Distress® on the other hand is an ideal tool for slow and variable speed shaft monitoring with its high signal to noise ratio.

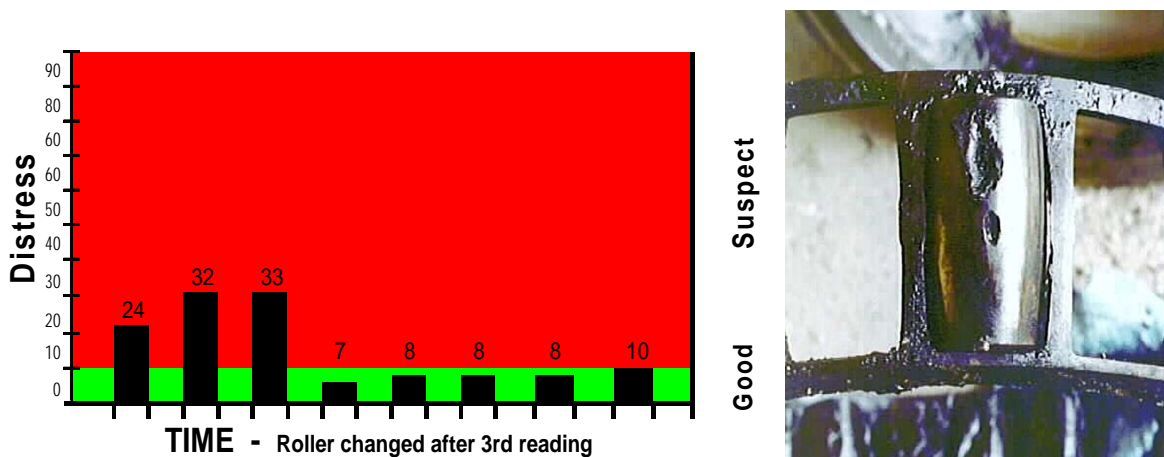


**Figure 8:**  
Distress® Measurement

## 7 CONDITION MONITORING OPTIONS FOR CONVEYORS

### 7.1 Off-Line AE Systems for Bearing & Lubrication Distress Monitoring

At Cleveland Potash UK, Dr Trevor Holroyd reported that his Bearing Distress® system had identified faults on conveyor tension rollers. **Figure 9** shows a progressive increase in bearing Distress® but the original reading, was in fact, above the threshold at the first measurement.



**Figure 9: AE Indicating Bearing Distress® Level and Severe Spalling on Roller**

Inspection of the suspect bearing, **Figure 9**, illustrates the seriousness of the fault with severe spalling on the bearing's roller. It has consistently been reported that AE signals are highly sensitive to the early stages of developing problems especially lubrication starvation. These attributes make AE especially suited to industrial shop-floor applications (noisy environments) and as a catch-all front-line technique. The technique applies to anti-friction as well as plain bearings.

Recently, Mechanalysis India Ltd undertook a consultancy project on a few strategic machines at a major integrated Steel Plant in India to demonstrate the effectiveness of the AE bearing Distress® system.. It was noted, on a BOS Converter trunnion, (operates at 1 rpm) and a large Conveyor drive (35 rpm) that both had significant Distress® levels. Subsequent checks with the Plant's powerful FFT vibration analysers and bearing test meters did not endorse the Distress® data and so the report was ignored. Three months later the BOS drive bearings seized causing 40 days lost steel production at a time of premium steel prices globally. Because of this failure, the earlier reported Conveyor bearing was re-examined again by traditional FFT vibration analysis techniques but still appeared to be OK. However, to play safe the plant engineer physically examined the 750mm diameter drive roll bearing. To his amazement, spalling the size of a pigeon's egg was observed on the bearing's inner race. The company has since procured their own AE instrument and are set to expand a variation of it for on-line measurements

## 7.2 On-Line Acoustic Emission Systems for Super Slow Machine Drives

The technology was developed at the Rolls Royce Advanced Research Laboratories in UK but was taken into industry by Dr. T. Holroyd. Super Slow machine measurement is defined <60 RPM, the Signal Processing looks at 4 parameters to assess the fault. These are:

1. **db Level (db)** : A measure of the mean level of the high frequency 0-99db.
2. **Peak (P)** : Magnitude of worst region of activity (e.g. cracked bearing race) 0-99db.
3. **Intensity (I)** : Magnitude of surface condition over a damage region 0-99db.
4. **Extent (E)** : Value indicates the spread of damage 0-99%.

These indications are used to assess the condition of those bearings operating at super slow speeds. Amongst the present users are The London Eye giant wheel, BOS Converters in Corus Steel UK, Posco Steel Korea and several other similar sites.

**Figure 10**, courtesy of Corus Steel UK. The AE SloPoint system identified cracks on the inner race of their huge BOS Converter Trunnion Bearing that rotates around 1.5rpm. The acoustic emission bearing detection system prevented a catastrophic failure thus avoiding significant production losses.



**Figure 10:**  
Converter Bearing – Detected at 1.5 rpm

### 7.2.1 On-Line Intelligent Motor Condition Monitoring

Having addressed the portable and super slow detection systems we will now deal with the Conveyor Main Drive System. Usually this will be one or more motors rated from 200KW to 1.5MW with associated reduction gearboxes. Technology that was developed to assess the engines of the Space Shuttle for NASA is now available to intelligently monitor the electric motor drive train

The Motor Condition Monitor (MCM) is a small device (96x96x140D mm) that is installed in the existing motor switchgear panel and connected to the three-phase supply via the current transformers; wiring is minimal. Selected measurements can be displayed on the LCD screen of the device; alarms are presented using LED 'traffic lights' for warning Operations locally.

When installed, the MCM unit is activated for the LEARN stage (**Figure11**) where, for say the next 4 days, the unit will gather data on the machine's operating performance including process and will create a mathematical model of the same. The results are stored in its internal database. If the results obtained from the acquired data are significantly different from the reference model, MCM indicates a specific fault level taking into account the magnitude and the time duration of the difference.



**Figure 11 – MCM Unit**

Once the LEARN phase is completed MCM then goes into RUN mode monitoring the machine on-line. MCM, when connected to its SCADA display software, will report up to 12 mechanical faults and 8 electrical faults listed below. Complementary diagnostic instruments can then identify the specific fault location in the machine train if greater detail is needed.

**Electrical Parameters (8):**

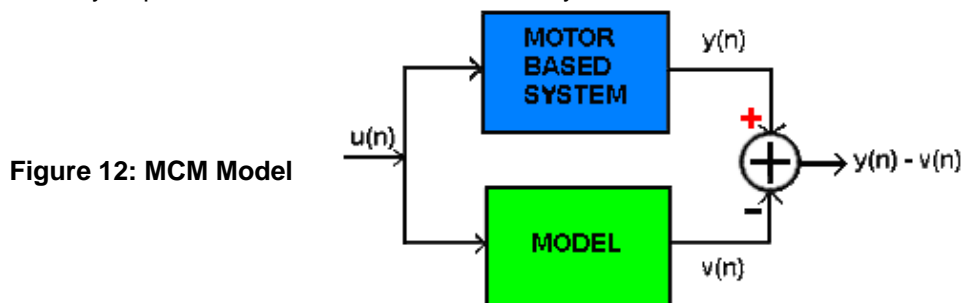
1. Stator insulation
2. Rotor bar
3. Voltage imbalance
4. Cabling isolation problems
5. Capacitor
6. Motor connector
7. Terminal slackness
8. Defective contactors

**Mechanical Parameters (12):**

- |                    |                              |
|--------------------|------------------------------|
| 1. Unbalance       | 7. Foundation looseness      |
| 2. Coupling        | 8. Oil whirl                 |
| 3. Misalignment    | 9. Belt/transmission defects |
| 4. Bent shaft      | 10. Motor Bearing defects    |
| 5. Rotor looseness | 11. Gear defects             |
| 6. Eccentric rotor | 12. Cavitation               |

**7.2.2 How Does MCM Work?**

MCM uses model-based fault detection and diagnosis techniques. The illustration below shows the principle approach used to compare the dynamic behaviour of the mathematical model of the machinery or process with the actual measured dynamic behaviour.



**Figure 12: MCM Model**

**Figure 12**, shows  $u(n)$  as the input voltage to both the mathematical model and the actual motor-based system,  $y(n)$  corresponds to the output of the motor-based system, i.e. the measured currents, and  $v(n)$  is the current calculated by the model. Therefore,  $y(n)-v(n)$  is the difference between the measured and calculated currents. The model consists of a set of differential equations that describes the electromechanical behaviour of the motor/generator. System identification algorithms for the calculation of model parameters process the real-time data acquired from the system. Faults developing in the motor or in the motor-driven system affect the model parameters, allowing the motor itself to be used as a condition monitoring sensor.

MCM monitors and compares 22 different model parameters that are classified into three main Groups.

**Group 1:** The eight 'electrical parameters' are the network equivalent parameters and are correlated to the physical parameters of the motor, like inductances and resistances. These parameters are sensitive to electrical faults developing in the motor. Though they are primarily used to detect electrical problems, they also can indicate incipient mechanical faults. For example, an imbalance or gear problem would cause dynamic eccentricity in the air gap, resulting in a change in the induction parameters. By monitoring the changes in these model parameters imbalance can be detected very early, avoiding damage to other machine components such as bearings.

**Group 2:** MCM also monitors the supply voltage as well as the load conditions. If the supply voltage changes abnormally, has imbalance or very high harmonic content then it issues a 'Watch Line' alarm. The 'Watch Load' alarm means that either the load conditions have changed or there is a fault developing in the electrical system.

**Group 3:** Using the measured three phase voltage and current signals, MCM calculates a set of physical parameters such as rms-values of three phase voltage and current, power factor, etc. Active and reactive power parameters in this set might be used for energy consumption estimations. It combines many measurements that are of interest to both production and electrical maintenance operators in a single device.

MCM can be integrated into a plant wide information system with its own desktop application. SCADA (Figure 13) that is used to provide the Operators with information (not data) outlining fault status with more analytical data available for maintenance engineers.

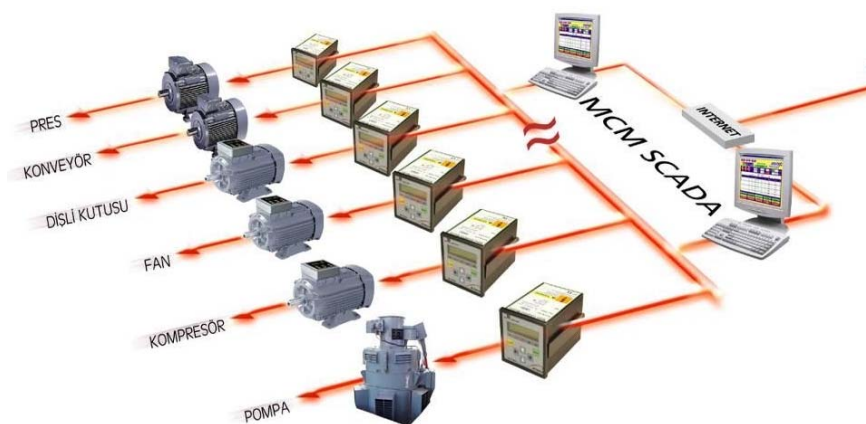


Figure 13: MCM SCADA Network

Average values obtained for energy consumption (voltage, current, active power, reactive power and power factor) as well as the power supply quality (THD, harmonics, voltage imbalance and current imbalance) are also provided. Operators are given summary warnings on the MCM display or via the SCADA software to remotely see an alarm and view a specific machine on-line. Figure 14 highlights the developing fault. By 'drilling down', detailed data such as trends and frequency spectrum is available. Note: M1-M12 indicate the mechanical faults while E1 onwards indicate the electrical faults and status. The various electrical performance parameters are always available especially the quality of the electrical supply.

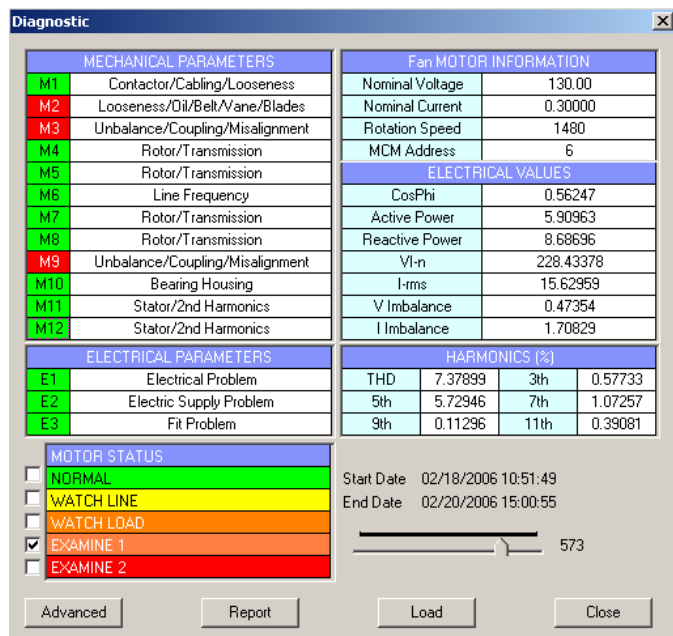


Figure 14: Operators Screen Display

### 7.2.3 MCM – Selected Successes and Applications

The MCM technology has been successfully deployed in a wide range of industries; over 6000 systems are in use in Europe alone. Recently introduced to India, MCM applied to Centac compressors in a steel plant provides comprehensive electrical machine status never available before. Their Electrical Department now no longer needs to employ external consultants to undertake motor current frequency analysis on a periodic basis

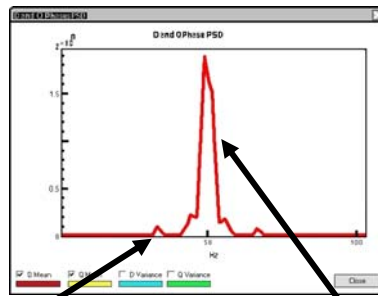
Many industries (power, primary metals, petrochemical processing, etc.) have considerable experience in condition monitoring techniques. They have found that MCM is able to identify faults that they were not aware even existed! Apart from the lower cost per installed channel, monitoring remote or inaccessible machinery for electrical and mechanical condition makes sense. These conditions seem to fit the Belt Conveyor category and some recent case studies are given below.

At London Heathrow Airport MCM units are installed at all Terminals including the newest T5 on escalators and the people conveyors (Paxcon). To reduce network cabling, data is transmitted via GPRS to the SCADA system in the Operators Control Room. Early successes have been achieved as illustrated in the following case studies:

**Figure 15.1** is a Chain driven escalator where MCM detected mechanical faults on the drive long before they became apparent. The MCM spectrum (15.2) indicates the alignment fault frequency. **Figure 15.3** shows the location of misalignment at the drive sprocket causing tooth wear.



**Figure 15.1**  
Chain driven Escalator monitored by MCM



**Figure 15.2**  
Bearing misalignment @ 16.25Hz (975RPM/60)  
Gearbox output shaft & chain misalignment @ 3 Hz



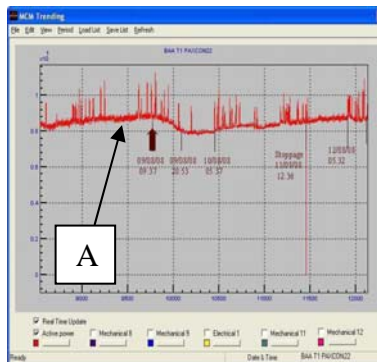
**Figure 15.3**  
Findings: 18mm misalignment (1.6°)  
5mm misalignment of chain sprockets  
Uneven chain running causing tooth wear.

**Figure 16** illustrates the use of the power trend line where the unloaded power was found variable. On further examination, an auxiliary motor was found inoperative:

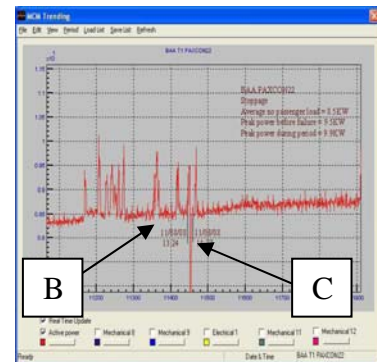


**Figure 16.1 Paxcon**

An unexpected passenger conveyance stoppage at an Airport can cause significant delays

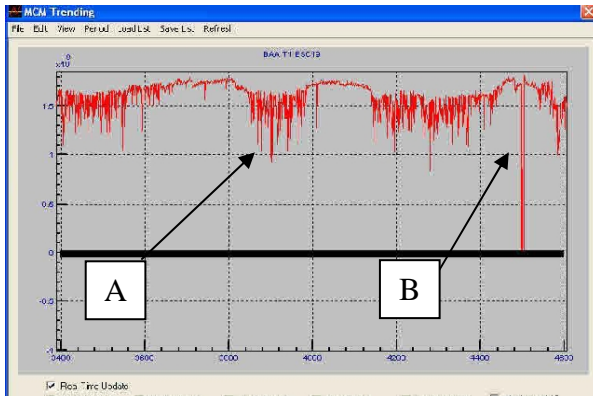


**Figure 16.2**  
**Active power trend line examined**  
PAXCON running all night at 10KW  
A - Unloaded power found variable?



**Figure 16.3**  
**Examined Incident in More Detail**  
B - Passengers loading from Gate.  
C - 63 minute stoppage whilst carrying passengers. Auxiliary motor not operative

The full capability and uses of MCM's detection power continues to be realised in a wide variety of manufacturing operations from assembling washing machines to the auto industry. In case study **Figures 17.1**, the 'Running Down Escalator' passenger load exhibits undesirable harmonics in the power system, indicative of a motor fault (**Figure 17.2**).

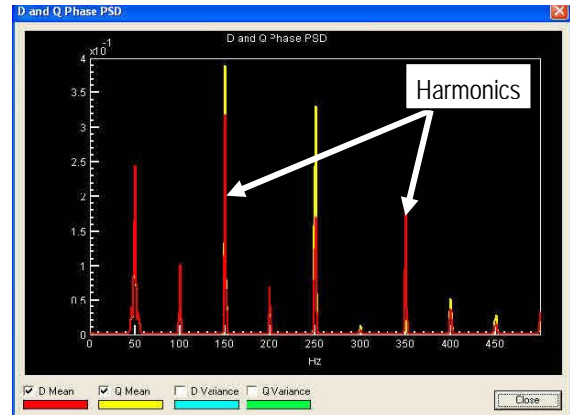


**Figure 17.1 Running Down Escalator**

A- Passenger load decreases electrical power drawn, escalator becomes re-generative.

B -Planned stoppage during night time

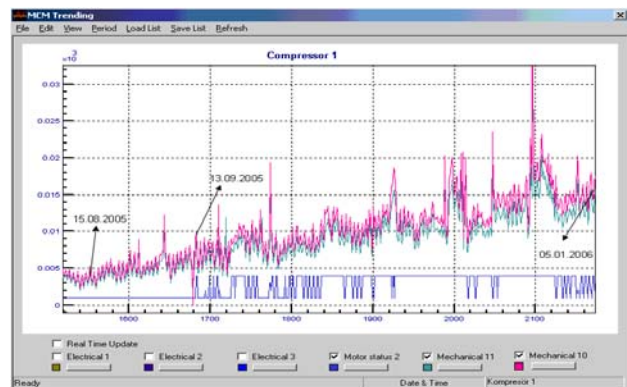
**Note:** The power level at night during unloaded times are different, does this indicate changing condition?



**Figure 17.2 Harmonic Wave Analysis**

Harmonics at 150Hz and 350Hz indicate motor problem.

**Figure 18**, illustrates the trend of a compressor where MCM has correctly identified the early development of bearing fault. It provided a 3-month warning to enable the successful planning of a maintenance intervention. This trend also shows that MCM was aware of the incipient defect for a full month before considering it sufficiently serious to alert maintenance staff.



**FIGURE 18 - Bearing Failure Advance Warning**

Often one observes condition monitoring systems being applied as fire-fighting tools. Instead of monitoring machinery trends, many systems are only employed when a machine is noticeably 'jumping around'. Only then are

the diagnostic instruments dusted off, perhaps the manual is read, (staff usually forget how to use the equipment) and then an attempt made at diagnostics. This is not how condition based maintenance was intended nor will the investment deliver the potential benefits. **Figure 18** clearly illustrates that with application of the right tools, managed condition monitoring will pay dividends many times over by giving advanced warning for proactive maintenance.

## 8 CLOSING COMMENTS

It is an established fact that rotating machines: fans, pumps, motors, generators, etc. will consume as much as 15% more energy if misaligned or out of balance. Worn or poorly lubricated bearings will contribute to such energy losses. Vibration, Acoustic Emission and the MCM Electro-Mechanical Condition Management Systems will identify and allow correction of rotating machines consuming excessive energy. Since conveyors fall into the same category, by optimising machinery performance, precious energy and hence environmental savings are possible.

Traditional on and off-line vibration monitoring systems have proved their worth yet machines continue to fail at the most inconvenient time. Until now, no effective solution was available for the effective monitoring of both mechanical and electrical process plant. The intelligent on-line MCM system that 'learns' the machine's process characteristics gives advanced fault notifications of the

deviations to the model created. Complemented by acoustic emission systems for super slow machine monitoring and checking remote conveyor drives, guides and idlers etc, reliance on diagnostic consultants or experts is no longer essential. These new cost effective tools will strengthen the armoury of the Maintenance and Operations Director to improve conveyor availability.

This paper has discussed two complementary sensitive techniques that provide advance warning of impending trouble of the drive system and associated elements. Other technologies, including lubrication health analysis to infrared thermography, will quantify defects at the advanced stage but by then it is a damage limitation exercise. With the advent of the on-line electric motor condition monitor for the main drive systems and AE for the passive rollers and the guides, effective predictive maintenance becomes a reality. Thus operational staff will be able to take objective production decisions that will keep conveyors conveying.

ooOoo

**Acknowledgement:** A. R. Maycock, President AMEC Chile, former Wright Eng. Canada & ZCCM Ltd. Zambia.

## REFERENCES

- Hills, P. W.** (2009) : **Condition Monitoring Keeps Conveyors Conveying**, International Conference on Conveyors, Beltcon15 Johannesburg South Africa
- Spriggs, G. H.** (2007) : **The Golden Rules Belt Conveyor Loadings and Forces**, Beltcon14 South Africa.
- Lebedev, Dr A** (2007) : **Dynamic Simulation of Conveyor Systems in Underground Hard Rock Mines**, Beltcon14 Conference, South Africa.
- Kruse, D. J.** (2007) : **Data Acquisition Techniques and Measurement Equipment for Belt Conveyors**, Beltcon14 South Africa.
- Hills, P. W.** (2007) : **Exceptional Condition Monitoring – The way forward for outsources services** CM Conference by Federation of Indian Chamber of Commerce, New Delhi India.
- Bates, A** (2007) : **Using Advanced Modelling Techniques to Simplify, Improve and Reduce Costs of Condition Monitoring** - Advances in Process and Condition Monitoring in the Offshore Oil Industry ACTC 2007 UK.
- Taylor, I \*** (2007) : **Condition Monitoring Using Acoustic Emission Monitoring the Development of Aquilla AE PRO, A Fixed System**, Corus Northern Engineering Services, UK (\* Also contributed by Peacock, K, Scatchard, D).
- Hills, P. W.** (2006) : **Keeping Condition Monitoring in Condition**  
National Conference on Condition Monitoring, Visakhapatnam, India.
- Holroyd, Dr. T.J.** (2006) : **Use of AE based Instrumentation to Monitor Machinery Condition in the Industrial Environment**, COMADEM UK.
- Holroyd, Dr. T. J.** (2004) : **Monitoring Slowly Rotating Machinery, Patent Number GB2376299**
- Hills, P. W.** (2001) : **Plant Asset Management** - CM2001 Oxford University, UK.
- Distress<sup>(R)</sup>** - Registered Trade Mark of Holroyd-instruments Ltd UK – [www.holroyd-instruments.com](http://www.holroyd-instruments.com)  
**MCM** - Is a patented technology from Artesis A.S. - [www.artesis.com](http://www.artesis.com)  
**Mechanalysis India Ltd.** - [www.mechanalysisindia.com](http://www.mechanalysisindia.com)

# Mechanalysis (India) Ltd



## Engineering the Environment

### The Mechanalysis Approach

*Getting you started*

*Keeping you going*

*Taking you further*

[www.mechanalysisIndia.com](http://www.mechanalysisIndia.com)

The Vibration People of Mechanalysis (India) Ltd can be contacted at any one of the following Branches

Mumbai	Delhi	Kolkata	Chennai
Tel: +91(0)22-2852-0178 Fax: +91(0)22-2852-1814 <a href="mailto:mumsa@mechanalysisindia.com">mumsa@mechanalysisindia.com</a>	Tel: +91(0)11-2237-3916 Fax: +91(0)11-2237-0778 <a href="mailto:delsa@mechanalysisindia.com">delsa@mechanalysisindia.com</a>	Tel: +91(0)33-2355-2062 Fax: +91(0)33-2355-9214 <a href="mailto:kolsa@mechanalysisindia.com">kolsa@mechanalysisindia.com</a>	Tel: +91(0)44-2823-0726 Fax: +91(0)44-2823-4702 <a href="mailto:chensa@mechanalysisindia.com">chensa@mechanalysisindia.com</a>